

For Residential and Commercial Applications

Job Name _____
 Job Location _____
 Engineer _____
 Approval _____

Contractor _____
 Approval _____
 Contractor's P.O. No. _____
 Representative _____

SunStat View™ Programmable Thermostat

120 or 240 VAC

The SunStat Programmable Thermostat is designed to control HeatWeave® Mat, WarmWire®, UnderFloor™, and SlabHeat™ resistive floor heating systems.

Specifications

DESCRIPTION	PROPERTY
Operation Voltage	120/240 VAC, 50/60 Hz
Maximum Load	15 amps, resistive
Maximum Power	1800 watts at 120VAC 3600 watts at 240VAC
GFCI	Class A (5 milliamp trip)
Display range	32 °F to 99 °F (0 °C to 37 °C)
Setting range	40 °F to 99 °F (4 °C to 37 °C)
Accuracy	+/-0.9 °F (0.5 °C)
Storage Temp	0 °F to 120 °F (-17 °C to 49 °C)
Memory	Programming retained indefinitely. Current time and day will need re-set if power is lost more than 30 minutes.

Features

- 15' floor sensor included
- Dual Voltage: 120 and 240 VAC
- Built-in 15-amp Relays
- Built-in GFCI (5 milliamp trip)
- "Masterstat" capability
- Connects directly to SunStat Relay II
- SmartStart Technology
- 7 Day Programming
- Preset Program Schedule
- Customize Program Schedule
- Floor, or air & floor temperature modes
- Display in degree F or degree C
- Large Color Touchscreen Display
- Keyboard Lock
- Manual On/Off Switch
- System usage monitoring

⚠ CAUTION

Before continuing, make sure the power supply voltage matches the voltage rating of the floor warming system. Connecting 240V to a 120V floor warming system will cause overheating and damage to the system and may damage the control, other wiring, floor coverings, etc.

⚠ CAUTION

This Engineering Sheet is not intended to provide full installation instructions and safety information. In order to avoid property damage or injury, please refer to the complete installation manual and product safety information provided with the product.



SunStat Pro II Programmable Thermostat

Installation Parameters

1. Determine the SunStat location:
 - Indoor use only.
 - Insulated or uninsulated walls.
 - Locate the SunStat approximately 5 feet above the floor on an inside wall.
 - Avoid placing near other heat sources or vents.
 - Install an appropriate sized electrical box (see SunStat Installation Manual)
2. Prepare the Wiring
 - Turn off the power at the main circuit panel before doing any electrical work.
 - A qualified electrician should install a properly sized circuit breaker.
 - A qualified electrician should run dedicated wiring for SunStat.
3. Pull supply power wiring into box, leaving about 6 inches of wire.
4. Pull the floor sensor wire and the power lead wires from the floor warming system up the wall, into this box.
5. Remove the SunStat face and connect wires (for wiring details see schematics on reverse)
6. Install SunStat in electrical box and re-install face.

Note: For detailed instructions, refer to the specific system installation manual.

✓	DESCRIPTION	MODEL #	ORDER #
	SunStat Pro II Programmable	500775-SB	81015385
	Extra SunStat Sensor (optional)	500110	81010277

Watts product specifications in U.S. customary units and metric are approximate and are provided for reference only. For precise measurements, please contact Watts Technical Service. Watts reserves the right to change or modify product design, construction, specifications, or materials without prior notice and without incurring any obligation to make such changes and modifications on Watts products previously or subsequently sold.



Electrical Wiring Diagram for Cable with SunStat Control (120/240VAC)
 Dedicated 120 or 240VAC, 20-amp (maximum) circuit (maximum 15 amp load through SunStat control).

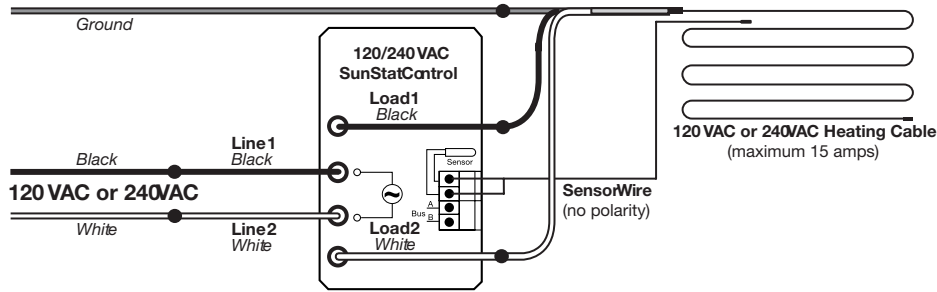

Electrical Wiring Diagram for Multiple Cables with SunStat Control (120/240VAC)
 Dedicated 120 or 240VAC, 20-amp (maximum) circuit (maximum 15 amp load through SunStat control).

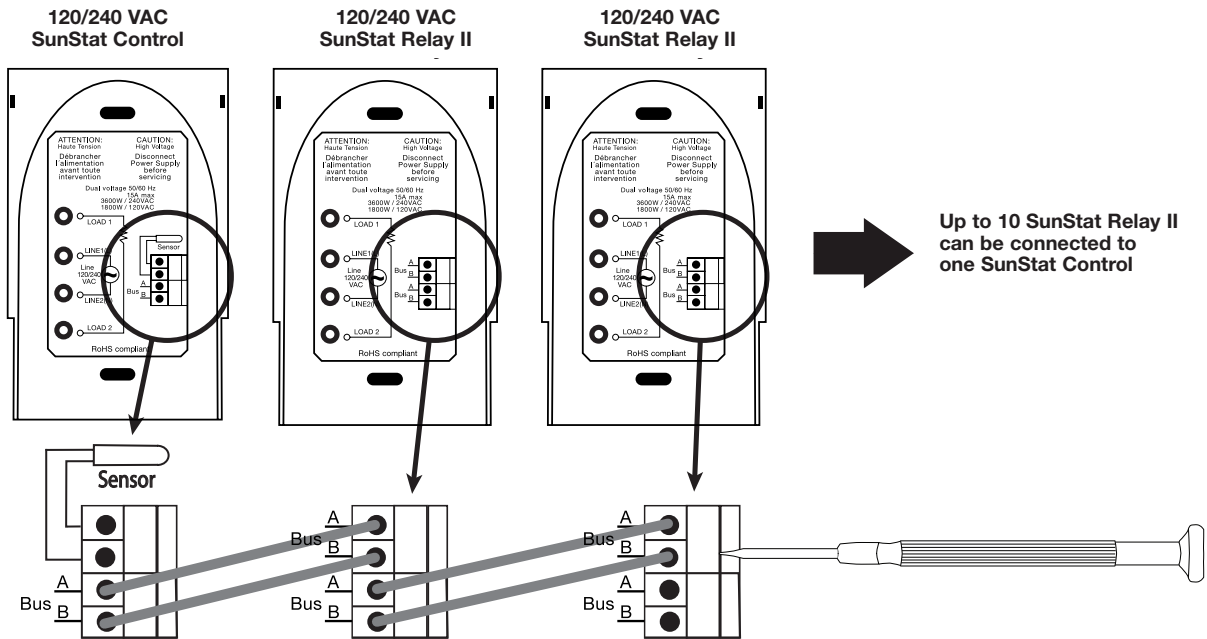
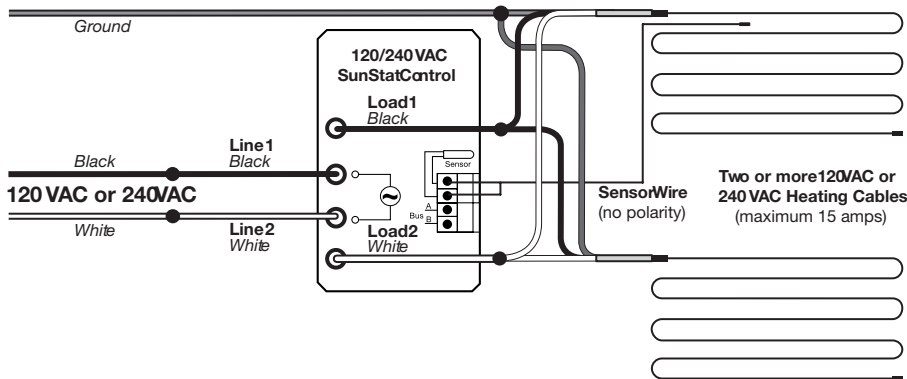

USA: Tel: (800) 276-2419 • Fax: (417) 864-8161 • Watts.com
 Canada: Tel: (905) 332-4090 • Fax: (905) 332-7068 • Watts.ca
 Latin America: Tel: (62) 81-1001-8600 • Watts.com